



DENSITRAK® D625

The DENSITRAK® Model D625 liquid density meter utilizes the spring mass principle for measuring the fluid density. A portion of the “u” tube is energized to vibrate at its natural resonant frequency by using an electrical feedback driving system. A change in the vibrating mass, (as a result of change in the fluid density) shifts the resonant frequency.

A CSI SPUD signal processing unit for density uses temperature, pressure and the shift in frequency to determine the density of the measured fluid.

Liquid density meter

Features:

- High resolution
- Superior quality
- Material addresses most corrosive applications
- Built-in RTD & temp. transmitter
- High benefit to cost ratio
- Frequency output for standard density calculation.
- Available with linearized 4-20 ma output
- One Year Warranty

Applications:

- Interface Detection
- Density Monitoring
- Product Blending
- Process Quality Control

Industries:

- Petroleum Pipeline & Refinery
- Chemical & Petro Chemical
- Automotive Production
- Food, Dairy & Beverages
- Pharmaceutical
- Water Treatment
- Semiconductor Production



Signal processing units for density

SPUD 620

The Model 620 is a small footprint density processor that can be installed on the DENSITRAK. Model 620 provides a frequency output signal or linearized 4-20 mA output over a specified density range. The Model 620 features a user selectable smart filtering feature, which provides a reliable density output in the real world environment of mechanical and hydraulic noise.

Features:

- Mounted integral to Densitrak
- Adjustable analog output
- Frequency output
- User defined alarms
- Smart density output filtering
- Optional 2 line LCD display

Data I/O Inputs:

- Density meter frequency
- Two temperature inputs
- Pressure input
- RS232 serial port (I/O)

Outputs:

- 4-20 mA current (programmable)
- Two dry contact alarm relays (1 amp)
- Isolated frequency (61 Hz to 10 kHz)
- LCD display (Optional)

Built in SPUD 620



Specifications

Calibrated density ranges:

Standard: 0.77 – 1.4 g/cc

Optional: 0.3 – 0.77 or 1.2 – 2.0 g/cc

Maximum density ranges:

0.7 g/cc

Signal output:

Nom. 0.8 kHz to 1.5 kHz

Amplitude out same as input voltage

Density resolution:

0.0001 g/cm³

Density meter accuracy:

0.0001 g/cm³*

Repeatability:

Better than 0.01%*

(*) Based upon density meter's raw frequency output. Field accuracy of the density reading ultimately depends upon the collective effects (RMS) of all measurement standards of density, temperature, pressure input during calibration, operational data collection and processing

Operating temperature:

Standard: 50°F to 140°F (10°C to 60°C)

Optional: 32°F to 240°F (0°C to 110°C)

Power requirement:

Voltage: 18 – 32 VDC

Current: 30 mA nom.

Temperature transmitter output:

Current: 4 – 20 mA

Operating pressure:

Standard calibrated pressure: 1500 PSI

Maximum line pressure: 2500 PSI @ 100F

Hydrostatic test: 1.5 times line pressure

Materials of construction:

316 SS body, Alloy C-276 tubes, Viton "O" rings

Electrical classification:

Designed to meet NEC Class 1, Div. 1, Group C&D

CE Mark

Instrument housing approvals: CSA, FM, EExd, UL

Principle of operation

The DENSITRAK® Model D625 liquid density meter uses the spring mass principle for measuring the fluid density. A portion of the "U" tube is energized to vibrate and to maintain its natural resonant frequency by using an electrical feedback driving system. A change in the vibrating mass, (as a result of change in the fluid density) shifts the resonant frequency. A density meter signal processing unit or flow computer uses temperature, pressure and the shift in frequency to determine the density of the measured fluid.

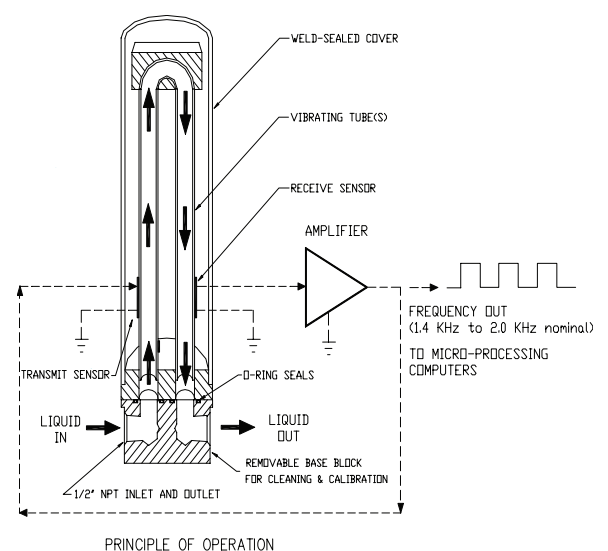

Identification code

Pos 1, 2, 3, 4	Model
D 6 2 5	-U- Tube density meter
	Pos 5 Separator
	-
	Pos 6 Wetted material
A	316
	Pos 7 Wetted process connection type
0	Standard 1/2" FNPT base only
1	With 1/2" 150# ANSI RF
2	With 1/2" 150# ANSI FF
3	With 1/2" 300# / 600# RF
4	With 1/2" 300# / 600# FF
5	With 1/2" 900# RF
6	With 1/2" 900# FF
7	With 35mm DIN
8	With 1/2" Male NPT
9	With M35
A	With 3/4" JIC
B	With 35mm JIS 10K
C	IS 3" RF 150# flange (scoop length)
D	IS 300# / 600# flange
E	IS 3" Ring Joint 900# Flange
	Pos 8, 9 Scoop length for "IS configuration"
0 0	No scoops
0 4	Desired length 4 Inches
0 5	Desired length 5 Inches
0 6	Desired length 6 Inches
0 7	Desired length 7 Inches
0 8	Desired length 8 Inches
0 9	Desired length 9 Inches
1 0	Desired length 10 Inches
1 1	Desired length 11 Inches
1 2	Desired length 12 Inches
1 3	Desired length 13 Inches
1 4	Desired length 14 Inches
1 5	Desired length 15 Inches
1 6	Desired length 16 Inches
	Pos 10 Wetted Process connection material
0	316 / 316L
1	304/304L
2	C-276
	Pos 11 Electronics package
0	Amplified module without density processor Frequency output signal
1	Amplified module with SPUD 620 processor in NEMA 4 enclosure, 4-20 mA output for density
2	Amplified module with SPUD 620 processor in NEMA 4/7 explosion proof enclosure, 4-20 mA output for density

D	6	2	5	-	A	0	1	4	0	2	Typical identification code
D	6	2	5	-							Your identification code

Physical configuration

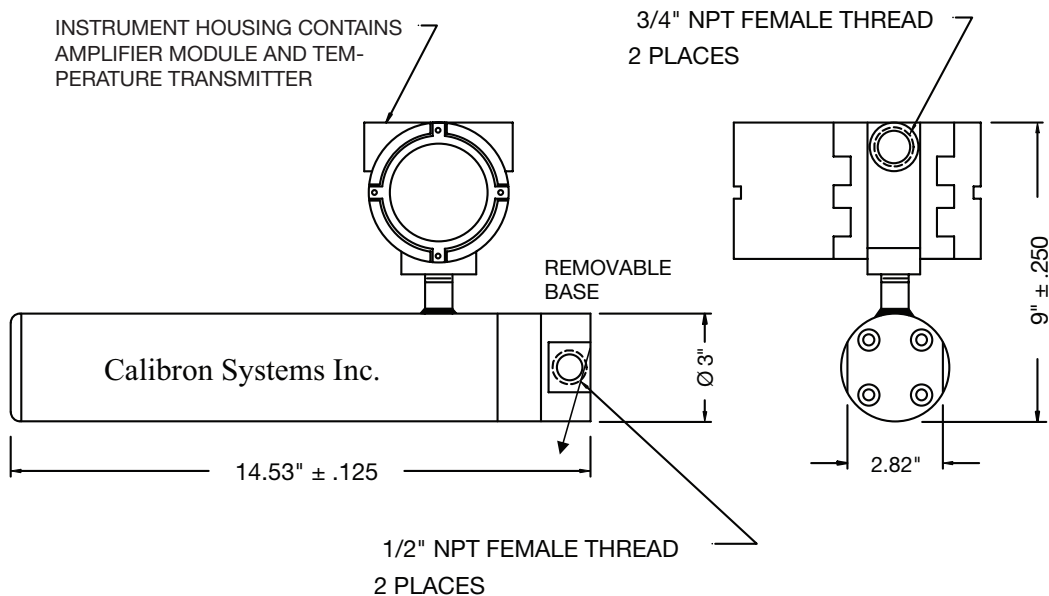

Honeywell Enraf

Honeywell Enraf

2000 Northfield Court
Roswell, GA 30076 USA
Tel: +1 770 475-1900
www.honeywell.com/ps

EN-09-12-ENG
June 2009
© 2009 Honeywell International Inc.