



A compact, intelligent and reliable Advanced Tank Gauge

As tank gauging has evolved, the series 854ATG servo level gauge has become an industrial standard all over the world. Very reliable, versatile and accurate automatic tank gauge with a minimum of moving parts, meeting all international standards, regulations and recommendations. A true test of its quality is the dependability and low warranty record that the ATG has maintained for many years. The multi-functional instrument is modularly constructed. The option slots for additional features allow connecting to a wide range of other instruments e.g. temperature-, pressure-, interface measurement and more. Obviously the connectivity to various field busses and tank inventory or host systems can easily be accomplished. Simple configuration and diagnostics are possible through a hand held device or via configuration software.

Measuring specifications

Measuring range	: Standard 27 m (88 ft) Optional 37 m (121 ft) 35 m (115 ft) (with measuring wire up to 150 m (492 ft))
Measuring accuracy level	: $\leq \pm 0.4$ mm (± 0.016 ") ¹⁾
Measuring accuracy interface	: $\leq \pm 2$ mm (± 0.08 ") ²⁾
Measuring accuracy density	: $\leq \pm 3$ kg/m ³ (± 0.19 lb/ft ³) ³⁾
Measuring accuracy temp.	: ± 0.1 °C (± 0.18 °F) ^{1) 4)}
Sensitivity	: ± 0.1 mm (± 0.004 ") ¹⁾
Repeatability	: ± 0.1 mm (± 0.004 ") ¹⁾
Wave integration time	: Programmable, three setpoints, between 0.5 s and 10 s

Mechanical

Flange	: See 'Identification code', Pos 9, 10
Dimensions	: See back page
Weight	: Medium pressure version 16 kg (35 lb) Chemical version 21 kg (46 lb) High pressure version 26 kg (57 lb)
Cable entries	: 4 pcs ¾" NPT threaded

Environmental

Operating pressure	: M and C version : up to 6 bar / 0.6 MPa (90 psi) H version : up to 40 bar / 4 MPa (600 psi) (up to 25 bar / 2.5 MPa in acc. to PED)
Ambient temperature	: -40 °C to +65 °C (-40 °F to +149 °F)
Protection class	: IP 65 according to EN 60529 (NEMA 4)
Safety	: Explosion proof - II 1/2 G EEx d IIB T6 or EEx de IIB T6 or EEx d [ia/ib] IIB T6 or EEx de [ia/ib] IIB T6 according to ATEX - Class I, Division 1, Groups B, C and D, in acc. to ANSI / NFPA 70 (FM, USA)

Materials

Housing servo comp. & cover	: All types cast aluminum Int. reg. AA A356 EN1706 AC-AISi7Mg0.3
Drum compartment	: M version cast aluminum Int. reg. AA A356 EN1706 AC-AISi7Mg0.3 C & H version stainless steel ASTM A351, CF-8M, G-X6 CrNiMo 18 10 (1.4408)
Finish aluminum parts	: Chromatinized according to MIL-C-5541C
Measuring drum, drum shaft	: Stainless steel (1.4401) EN10088 \cong AISI 316
Measuring wire	: See 'Identification code', Pos 12
Magnet cap	: Stainless steel (1.3953)
O-rings	: Drum cover Silicone / FEP (others NBR 70)

Electrical

Power supply	: 110/130/220 V (+10% to -20%) and 230 V ($\pm 15\%$), optional 65 V (+10% to -20%), also suitable for 240 V (+10% to -20%)
Frequency variations	: 50 Hz to 60 Hz ($\pm 10\%$)
Power rating	: 25 VA, $I_{\max} = 2$ A

Transmission

Type	: Serial, ASCII coded, Bi-Phase Mark modulated (BPM)
Isolating voltage	: > 1,500 V
Lightning protection	: Full galvanic separation via isolating transformers
Protocol	: Standard Enraf fieldbus (GPU protocol)
Common mode rejection	: > 150 dB
Cabling	: Two conductors, twisted pair, $R_{\max} = 200$ Ω / line, $C_{\max} = 1$ μ F
Transmission to	
Portable Enraf Terminal (PET)	: Infra-red, serial

Options

Alarm relay outputs	: 2x SPDT, galvanically isolated, $V_{\max} = 50$ Vac or 75 Vdc, $I_{\max} = 3$ A
Density measurement	: See 'Identification code', Pos 15 (with density displacer)
Analog level output	: 4 - 20 mA (accuracy $\pm 0.1\%$ full scale)
Input boards	: Spot RTD, VITO probes for average temperature and/or water measurement, HART® devices
Data transmission	: Standard Modbus via RS-232C, RS-485 or Foundation Fieldbus® i.s. output for Tank Side Indicator (TSI)
Cable entries	: Adapters available to fit other sizes cable glands

HART® is a trademark of the HART Communications Foundation.

Foundation Fieldbus® is a trademark of the Fieldbus Foundation.

¹⁾ Under reference conditions

²⁾ Difference product density 100 kg/m³ (6.25 lb/ft³)

³⁾ (optional) with a density displacer and calibrated for density measurement

⁴⁾ With VITO temperature probe

Pos 1 Application									
U General purpose					X W&M certified				
Pos 2 Data transmission									
E Enraf Bi-phase mark protocol (standard)									
I i.s. Output for Tank Side Indicator (TSI) and Enraf Bi-Phase Mark (BPM) protocol									
R RS-232C GPU protocol (only when Pos 4 = B, C, J, U or Z)									
S RS-485 GPU protocol (only when Pos 4 = B, C, J, U or Z)									
V RS-232C standard Modbus (only when Pos 4 = B, C, J, U or Z)									
W RS-485 standard Modbus (only when Pos 4 = B, C, J, U or Z)									
O Foundation Fieldbus + BPM									
Pos 3 Display									
A With display									
Pos 4 I/O options									
B Spot temperature Pt100					W Analog level output + VITO temperature and/or water probe				
C VITO temperature and/or water probe					X Analog level output + VITO temperature probe				
J VITO temp. and/or water probe + HART device(s)					Y Analog level output + spot temperature Pt 100 + VITO temp. and/or water probe + HART device(s)				
U Spot temperature Pt100 + HART device(s)					Z None				
V Analog level output									
Pos 5, 6, 7 Instrument designation									
8 5 4 Servo gauge ATG									
Pos 8 Pressure version									
C Up to 6 bar 0.6 MPa (90 psi) if Pos 9, 10 = 11, 12 or 13									
M Up to 6 bar 0.6 MPa (90 psi) if Pos 9, 10 = 21 or 22									
H Up to 40 bar 4 MPa (600 psi) if Pos 9, 10 = 51, 52, 53 or 54 (25 bar according PED)									
Pos 9, 10 Drum compartment & flange									
		mat. *)	flange	acc. to	finish	compatible with	acc. to		
1	1	ss	2" 150 lbs rf	ANSI B16.5	turning, Ra = 3.2 - 12.5 µm	DN50, PN20 rf	ISO 7005-1		
1	2	ss	NW50 ND6 form D	DIN 2501 DIN 2526	turning, Rz = max. 40 µm	DN50, PN6 rf	ISO 7005-1		
1	3	ss	2" 150 lbs ff	ANSI B16.5	turning, Ra = 3.2 - 12.5 µm	DN50, PN20 ff	ISO 7005-1		
2	1	Al	2" 150 lbs ff	ANSI B16.5	turning, Ra = 3.2 - 12.5 µm	DN50, PN20 ff	ISO 7005-1		
2	2	Al	NW50 ND6 form B	DIN 2501 DIN 2526	turning, Rz = 40 - 160 µm	DN50, PN6 ff	ISO 7005-1		
5	1	ss	2" 300 lbs rf	ANSI B16.5	turning, Ra = 3.2 - 12.5 µm	DN50, PN50 rf	ISO 7005-1		
5	2	ss	2" 300 lbs rf	ANSI B16.5	turning, Ra = 3.2 - 6.3 µm	DN50, PN50 rf	ISO 7005-1		
5	3	ss	NW50 ND40 form C	DIN 2501 DIN 2526	turning, Rz = 40 - 160 µm	DN50, PN40 rf	ISO 7005-1		
5	4	ss	NW50 ND40 form E	DIN 2501 DIN 2526	turning, Rz = max. 16 µm	DN50, PN40 rf	ISO 7005-1	*) see also technical specifications	
Pos 11 Safety approvals									
A ATEX Europe					For other approvals please contact your nearest Enraf office				
C CSA Canada									
F FM USA									
Pos 12 Measuring range & wire material									
2 27 m (88 ft) AISI 316					K 37 m (121 ft) Hasteloy C22				
A 27 m (88 ft) Hasteloy C22					L 37 m (121 ft) Tantalum				
B 27 m (88 ft) Tantalum					M 37 m (121 ft) Invar				
C 27 m (88 ft) Invar					N 37 m (121 ft) Platinum / 20% Iridium				
D 27 m (88 ft) Platinum / 20% Iridium					9 35 m (115 ft) AISI 316 with 150 m (492 ft) wire length				
3 37 m (121 ft) AISI 316									
Pos 13 Purge connection									
* Option not used					L 1/4" BSP entry				
Pos 14 Mains supply									
A 220 V 50/60 Hz					R 130 V 50/60 Hz				
C 110 V 50/60 Hz					S 65 V 50/60 Hz				
K 230 V 50/60 Hz									
Pos 15 Density measurement									
D With servo density measurement					* Option not used				
Pos 16 Alarms									
W With 2 programmable SPDT alarms					Z No alarms				

U E A Z 8 5 4 M 2 1 A 2 * A * Z Typical identification code

A 8 5 4 Your identification code

Dimensional drawing

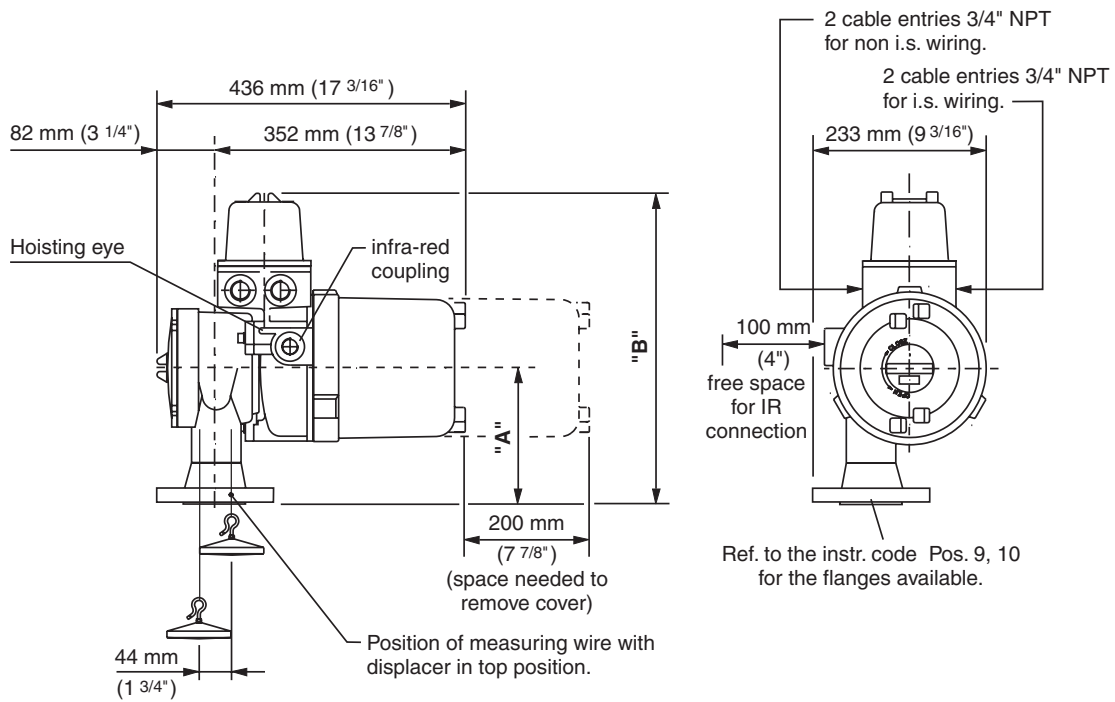

	"A"	"B"
M and C version	184 mm (7 1/4")	427 mm (16 13/16")
H version	206 mm (8 1/8")	449 mm (17 11/16")

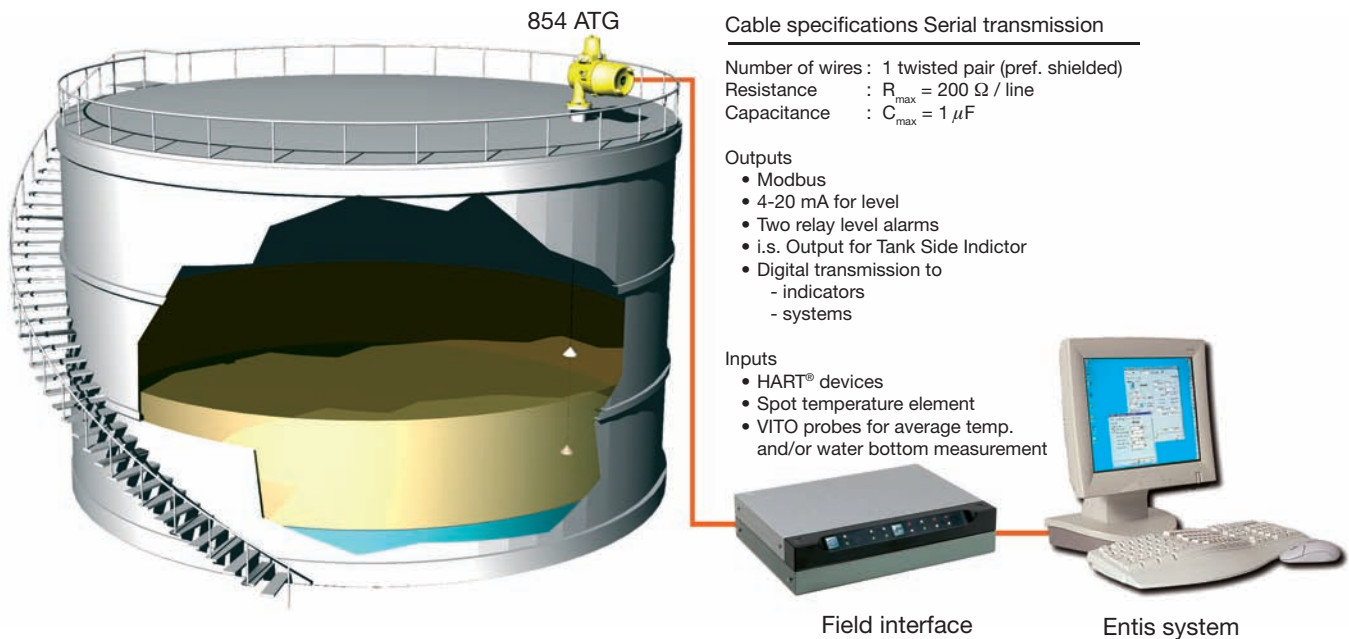

Honeywell Enraf

Delftechpark 39
 2628 XJ Delft
 The Netherlands
 Tel: +31 (0)15-2701 100
 E-mail: enraf-nl@honeywell.com
 www.honeywellenraf.com

PS-4417876-Rev.8-ENG
 March 2008
 © 2008 Honeywell International Inc.

Honeywell Enraf