



**The fit for purpose radar tank gauge for intermediate liquid product storage.**

Honeywell Enraf's proven technology and a number of innovative technological developments are combined in the SmartRadar LT to provide accurate and reliable level measurement data for even the most demanding intermediate storage applications. The non affected absolute accuracy of  $\pm 3\text{mm}$  over a measuring range of 40 meters grants an safe, reliable and efficient use of the available storage capacity, thus enabling the effective use of larger tanks for intermediate storage purposes. To prove this, the SmartRadar LT fully complies with the Worldwide recognised OIML standard and meets the recommended API industry practices for intermediate storage tanks. The broad range of exchangeable antenna's makes it possible to use this radar under various mounting conditions, from free space to still pipe, hinged or fixed, pressurized or atmospheric, providing a solution for every application.



**Identification code**

<b>Pos 1 Application</b>																	
U	API chapter 3.1 B compliant																
A	Including individual Enraf test report according OIML R85																
<b>Pos 2 Data transmission</b>																	
E	BPM (Bi-Phase Mark protocol) standard																
I	BPM + i.s. output for 977 TSI (Tank Side Indicator)																
H	HART and 4-20 mA output + BPM																
K	HART and 4-20 mA output, i.s. output for 977 TSI + BPM																
R	RS-232C GPU protocol																
S	RS-485 GPU protocol																
T	RS-232C GPU protocol and i.s. output for 977 TSI																
U	RS-485 GPU protocol and i.s. output for 977 TSI																
V	RS-232C standard Modbus																
W	RS-485 standard Modbus																
X	RS-232C standard Modbus and i.s. output for 977 TSI																
Y	RS-485 standard Modbus and i.s. output for 977 TSI																
F	Foundation Fieldbus + i.s. output for 977 TSI + BPM																
O	Foundation Fieldbus + BPM																
<b>Pos 3 Pressure version</b>																	
A	Atmospheric																
M	Medium pressure 6 bar / 600 kPa (87 psi)																
H	High pressure up to 40 bar / 4 MPa (580 psi) (only if Pos. 1=U)																
<b>Pos 4 I/O options</b>																	
B	Spot temperature Pt100																
C	VITO temperature and/or water probe																
J	VITO temperature and/or water probe + HART device(s)																
U	Spot temperature Pt100 + HART device(s)																
Y	Spot temperature Pt 100 + VITO temperature and/or water probe + HART device(s)																
Z	None																
<b>Pos 5, 6, 7 Instrument designation</b>																	
9	7	3	SmartRadar LT														
<b>Pos 8 Safety approvals</b>																	
A	ATEX Europe																
F	FM/FCC USA																
For other approvals please contact your nearest Honeywell Enraf office																	
<b>Pos 9 Alarms</b>																	
W	With 2x SPDT alarm output																
Z	None																
<b>Pos 10 Mains supply</b>																	
B	110 Vac - 240 Vac (+10% / -20%), 45 / 65 Hz																
D	24 Vdc - 64 Vdc (+10% / -20%)																
<b>Pos 11, 12, 13 SmartRadar antenna's</b>																	
D	0	4	4" ROD antenna, free space														
F	0	6	6" PAT, free space														
F	0	8	8" PAT, free space														
H	0	4	4" CONE, still pipe, High Pressure (40 Bar)														
S	0	6	6" PAT, still pipe														
S	0	8	8" PAT, still pipe														
S	1	0	10" PAT, still pipe														
S	1	2	12" PAT, still pipe														
T	0	6	6" WALP, free space, hingeable version														
W	0	6	6" WALP, free space, fixed version														
<b>Pos 14, 15 Stem length / Installation specification</b>																	
0	5	5 cm (only if Pos. 11=F, S or W)															
3	0	30 cm (only if Pos. 11=F, S or W)															
5	0	50 cm (only if Pos. 11=F, S or W)															
8	0	80 cm (only if Pos. 11=F, S or W)															
B	1	Installation on 6"300 lbs nozzle with 4" Schedule 10 stilling well (only if Pos. 11=H)															
B	4	Installation on 4"300 lbs full bore ball valve (only if Pos. 11=H)															
N	1	Installation on 6"300 lbs nozzle with 4" Schedule 10 stilling well including 1" full bore ball valve (only if Pos. 11=H)															
N	4	Installation on 4"300 lbs Schedule 40 nozzle including 1" full bore ball valve (only if Pos. 11=H)															
<b>Pos 16 IR connection</b>																	
W	With IR-connector																
Z	Without IR-connector																
U	E	A	Z	9	7	3	A	Z	B	F	0	8	3	0	W	<b>Typical identification code</b>	
				9	7	3											<b>Your identification code</b>

## Outputs

- Standard : Enraf Bi-Phase Mark communication  
 Optional : - RS-232C or RS-485 (GPU or Modbus)  
 - HART® & 4-20 mA level output  
 - Foundation Fieldbus H1

## For communication to indicators and systems

- Intrinsically-safe channel for the Tank Side Indicator (TSI)
- alarm outputs

## Inputs

- HART® devices
- Spot temperature element
- VITO probes for:
  - average product and gas temperature
  - temperature profiling
  - water bottom measurement

## Configuration

- Enraf service tool for use with a PC or laptop using Enraf Bi-Phase Mark communication, RS-232C, RS-485, HART® interface
- Portable Enraf Terminal (PET) using infra-red connector

## Display (optional)

- Field Display & Interface (FDI) and Control Panel Indicator (CPI) using Enraf Bi-Phase Mark communication
- Tank Side Indicator (TSI) using intrinsically-safe connection

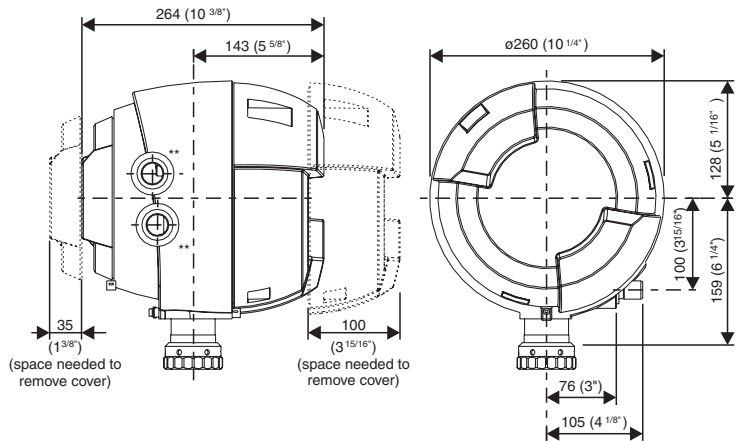

SmartRadar LT

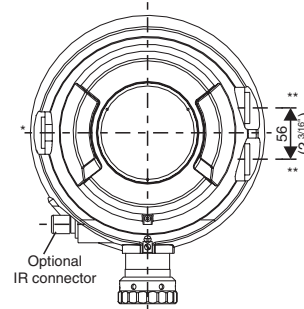

\* Cable entry 3/4" NPT, Ex-i (1x)  
 \*\* Cable entry 3/4" NPT (2x)



Field interface

Entis system

## Honeywell Enraf

Delftechpark 39  
 2628 XJ Delft  
 The Netherlands  
 Tel: +31 (0)15-2701 100  
 E-mail: enraf-nl@honeywell.com  
 www.honeywell.com/ps

4416845\_Rev7  
 May 2009  
 © 2009 Honeywell International Inc.

**Honeywell Enraf**